



Product ID: ZB-5008  
www.RGBgenie.com  
(520)-338-8849



## RGBgenie ZigBee 5 Zone Remote and Dimmer

Enjoy the convenience of operating your smart lights with a handheld remote. The ZB-5008 gives you fingertip control of color, on/off and dimming of 4 different Zones. Features include smooth fading with gentle off dimming, built-in effects, and white light temperature control. The ZB-5008 can bind up to 30 lighting devices and comes with 3 scene recall per zone.

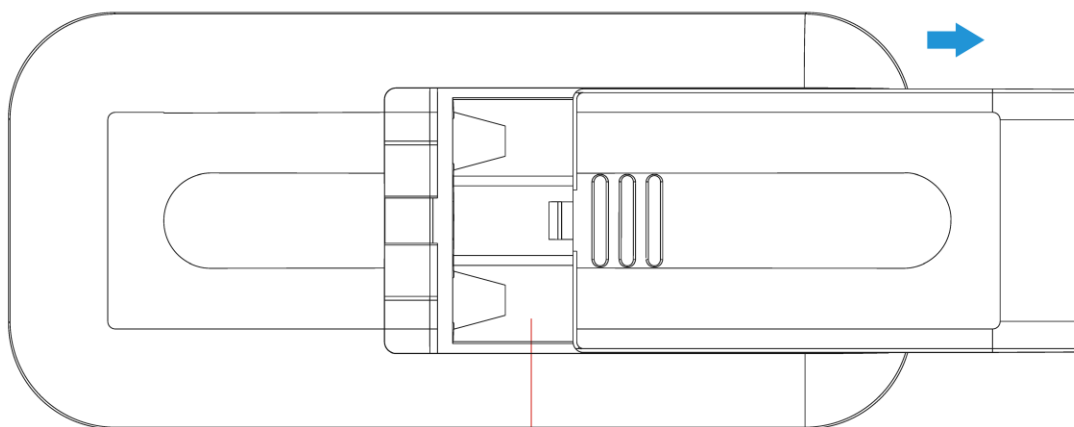

4.5V(3xAAA battery)

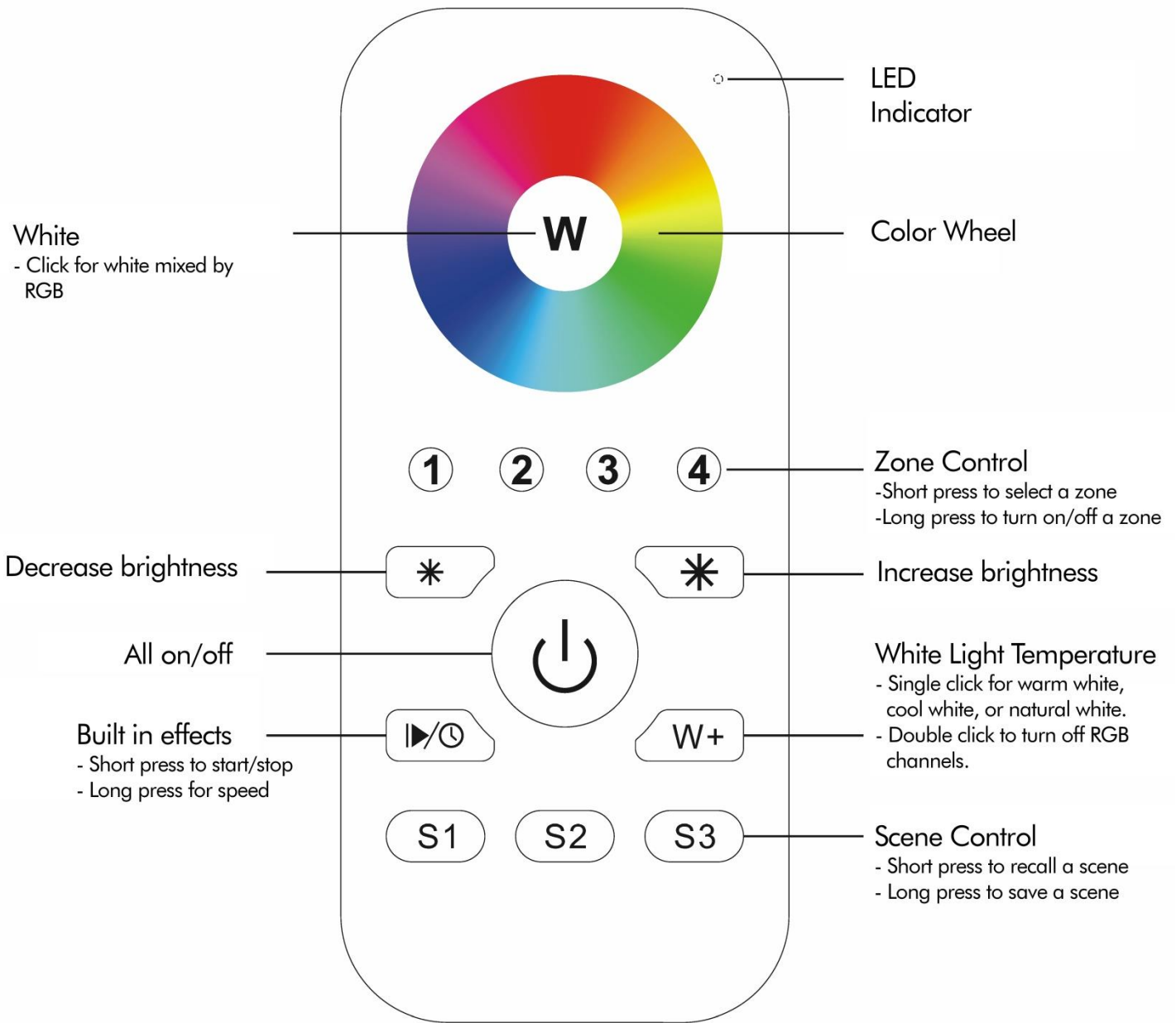

# INTRODUCTION

Thank you for choosing RGBgenie as your lighting control provider. This device is compliant with the ZigBee 3.0 standard which is the unification of the HA (Home Automation) and LL (Light Link) profile. This is an End Point Device that can perform all available operations within the standard. Using wireless signals at 2.4 GHz this product is also suitable for global operation. It has a line of sight transmission range of up to 100 feet. Transmission range is affected by dense objects, such as brick walls, refrigerators, solid doors or the like. For optimal performance, consideration should be given to placement.

This device supports 4 zones (also known as groups) and 3 scene control. It can bind up to 30 lighting devices for on/off, color, and dimming control. It is compatible with universal ZigBee gateway products and universal ZigBee lighting devices.

1	<u><a href="#">Adding to the ZigBee Network</a></u> .....	pg. 3
2	<u><a href="#">Checking for Network Inclusion</a></u> .....	pg. 4
3	<u><a href="#">Pairing to ZigBee Lighting Device Through Touch-Link</a></u> .....	pg. 4
4	<u><a href="#">Using the Remote to Reset a Device (ZIIResetToFactoryNewRequest)..</a></u>	pg. 5
5	<u><a href="#">Battery Power Monitor Function</a></u> .....	pg. 6
6	<u><a href="#">Pairing a Device Through Find and Bind Mode</a></u> .....	pg. 6
7	<u><a href="#">Unpair a Device Through Find and Bind Mode</a></u> .....	pg. 7
8	<u><a href="#">Clear All Paired Lighting Devices of a Group</a></u> .....	pg. 7
9	<u><a href="#">Binding the Remote with a Device in a Controller (Hub)</a></u> .....	pg. 8
10	<u><a href="#">Unbinding the Remote with a Device from a Controller (hub)</a></u> .....	pg. 8
11	<u><a href="#">Factory Reset Remote (Remove from a ZigBee Network)</a></u> .....	pg. 8
12	<u><a href="#">Supported ZigBee Clusters</a></u> .....	pg. 9
13	<u><a href="#">Products Data</a></u> .....	pg. 9

## 1. ADDING TO A ZIGBEE NETWORK

Before pairing to a ZigBee network, please make sure that the Remote does not belong to any prior network. When new, the Remote will be set to inclusion mode by default. If the Remote has been previously added to another ZigBee network it will need to be removed and reset.

From your ZigBee controller select the option to add a new device. Please refer to the instruction manual that came with the controller for adding a device.



From the Remote press and hold the All On/Off power button until the LED status indicator turns on.

S1

Immediately press the S1 button once for the Remote to search for nearby networks. The LED indicator will flash once every second.

Network pairing will begin automatically. The Remote will blink 6 times quickly when it has found your network and then turn off. The Remote should now appear in your controller's menu.

**IMPORTANT:** For the Philips Hue Bridge, no Remote information will appear in the App menu. The only indication of inclusion will come from the Remote so make sure to watch for the 6 quick blinks of the LED indicator.

You can check for inclusion by quickly pressing the All On/Off button and the LED indicator will blink once. If the indicator does not blink when quickly pressing All On/Off, it is still in factory default mode and not included in any network.

If no network is available, or one is not found, the Remote will timeout after 20 seconds and the indicator LED will turn off without blinking 6 times quickly. Repeat the inclusion operation from the beginning.

## 2. CHECKING FOR NETWORK INCLUSION

Quickly press the All On/Off or All Off button and the LED indicator should blink once. If the LED indicator does not respond, the Remote is not paired with a network.

## 3. PAIRING TO LIGHTING WITH TOUCH-LINK

The Remote can pair with lighting devices that support Touch-Link commissioning. Touch-Link is a proximity base mechanism which makes it easy to associate the devices with each other.

Note: This Remote does not need to be added to a ZigBee controller to be bound to another device via Touch-Link. However, the Remote is limited to pairing with only a single device when it is not included in a ZigBee network. When added to a network, the Remote can be paired with up to 30 devices.

Note: For Philips Hue and Amazon Echo Plus, add the Remote and lighting device(s) prior to attempting Touch-Link pairing.

Note: Philips Hue lighting needs the power to be cycled off and then on to initiate the Touch-Link protocol.

To start, the lighting device will need to be put into the Touch-Link mode. Please consult the device manual for this process.

Bring the lighting device to within 4 inches of the Remote.



Click the zone (1, 2, 3, or 4) you wish to assign the lighting to.



Immediately press and hold down the All On/Off button until the LED indicator turns red.

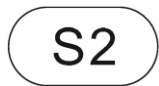

Click the S2 button to start the Touch-Link commissioning process with the remote.

The LED indicator on the Remote will flash quickly for 3 seconds to indicate the start of the process then flash six times slowly to indicate a successful connection. The lighting will flash twice.

#### 4. USING THE REMOTE TO RESET A DEVICE

Many lighting devices do not have a physical means to reset them to factory specifications if the controller becomes damaged or is missing. In this case, you can use the Remote to initiate a [ZIIResetToFactoryNewRequest] command. This is only recommended when a device reset is impossible with any other method. The Remote can either be part of the same ZigBee network or not added to any network at all. This command may not function

if the Remote is part of a different ZigBee network so the remote will need to be reset to factory defaults.

To start, the lighting device will need to be put into the Touch-Link mode. Please consult the device manual for this process.

Bring the Remote within 4 inches of the lighting device.



Press and hold down the All On/Off power button on the Remote until the LED indicator turns on.

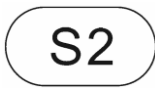

Immediately click the S2 5 times continuously send the factory reset command

The LED indicator on the Remote will flash quickly for 3 seconds and then flash 3 times slowly to indicate a successful reset.

## 5. BATTERY POWER MONITOR FUNCTION

The Remote will report battery power levels to the controller (hub) in 4 scenarios.

1. When the Remote is powered on.
2. When the Remote is operated after 4 hours of non-use.
3. When added to a controller (hub).
4. When both the S2 and S3 buttons are pressed simultaneously.

## 6. PAIR A DEVICE THROUGH FIND AND BIND MODE

Finding and Binding a ZigBee device is different than Touch-Link in that it is not proximity based. Typically the association between devices with this method is done through a hub or controller.

For a lighting device to find and bind a target it needs to scan for nodes in the network. To start, the lighting device will be the initiator node. Please consult the device manual for this process.

 Click the On button of the zone (1, 2, 3, or 4) you wish to assign to lighting.

 Immediately press and hold down the All On/Off button until the LED indicator turns solid red.

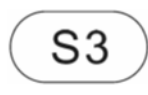
 Click the S3 button start the find and bind process with the remote. The Remote will be the target node.

The binding will be successful within 4 seconds and the LED on the Remote will flash 4 times. If binding fails the LED indicator will flash twice.

## 7. UNPAIR A DEVICE THROUGH FIND AND BIND MODE

Set the lighting device to find and bind a target in the network. The lighting device will be the initiator node. Please consult the device manual for this process.

For a lighting device to find and bind a target it needs to scan for nodes in the network. To start, the lighting device will be the initiator node. Please consult the device manual for this process.

 Click the zone button (1, 2, 3, or 4) the lighting device is bound to.

 Immediately press and hold down the All On/Off button until the LED indicator turns solid red.

 Click the Off button of zone 1 twice quickly to start the find and bind process with the remote. The Remote will be the target node.

The unbinding will be successful within 4 seconds and the LED on the Remote will flash 4 times. If unbinding fails the LED indicator will flash twice.

## 8. CLEAR ALL PAIRED LIGHTING DEVICES OF A GROUP

 Click the On button of the zone (1, 2, 3, 4 or 5) you wish to unbind devices.



Immediately press and hold down the All On/Off button until the LED indicator turns solid red.

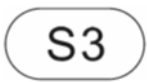

Click the S3 button five times quickly to clear all bound lighting devices within the zone.

The LED indicator on the remote will flash 4 times to indicate successful unbinding.

## **9. BINDING THE REMOTE WITH A LIGHTING DEVICE IN A CONTROLLER (HUB)**

After the Remote and target device have been added to the same network, click any button to activate the Remote. Then from your ZigBee controller interface choose to bind the device to the Remote as instructed by the manufacturer. The device can now be controlled by the Remote.

Once the binding operation is done, the Remote can still control the device in the event of controller (hub) loss or failure.

NOTE: Phillips Hue and Amazon Echo Plus do not support this function, please use Touch-Link to associate the devices. The Remote will still control the device in the event of controller (hub) loss or failure is Touch-Link is used.

## **10. UNBINDING THE REMOTE WITH A DEVICE IN A CONTROLLER (HUB)**

To unbind the Remote and lighting device, first, click any button to activate the Remote. Then from your ZigBee controller interface, choose to unbind the device from the Remote as instructed by the manufacturer.

NOTE: Phillips Hue and Amazon Echo Plus do not support this function, please use Touch-Link to associate the devices. The Remote will still control the device in the event of controller (hub) loss or failure is Touch-Link is used.

## **11. FACTORY RESET THE REMOTE**



If the Remote has been added to a ZigBee controller (hub), it is always best to remove the device from within the controller interface. Please see the manufacturer's user manual for controller interface instructions. The Remote will turn on and flash 3 times quickly to indicate a successful reset. If that is not possible or is unsuccessful, the Remote can be manually reset.

Note: All stored devices will be lost when the Remote is reset. The Remote will be restored to the factory default settings.



Press and hold down the All On/Off power button on the Remote until the LED indicator turns on.



Immediately and quickly press the All On/Off button 5 times. The LED indicator will flash three times quickly to indicate successful removal from the network and is now reset to factory default.

## 12. SUPPORTED ZIGBEE CLUSTERS

### Input Clusters:

- Basic
- Power configuration
- Identify
- Diagnostics

### Output Clusters:

- Identify
- Group
- Level Control
- On/off
- OTA
- Scene

## 13. PRODUCT DATA

Operation Frequency	2.4GHz	Operating temperature	32-85°F
Operating Voltage	4.5VDC	Relative humidity	8% to 80%
Transmission Range	100 Feet	Dimming Range	1%-100%
Protection Type	IP20	Dimensions	120x55x17mm
Protocol	ZigBee 3.0	Battery Type	AAA x 3